

MOD:XEVC-0621-GPLM



ENGLISH

TECHNICAL DATA

01 POWER	1 kW
03 FREQUENCY	50 / 60 Hz
04 POWER SUPPLY CABLE TYPE	H07RN-F
05 EXTERNAL Ø OF POWER SUPPLY CABLE	10 mm
06 VOLTAGE / POWER CABLE SECTION / CURRENT	220-240 V~1PH+N+PE 3G x 1,5 mm ² Circuit Breaker 10 A I1=4,5 A
10 WATER PRESSURE	150-600 kPa
11 MAX FOOD LOAD	60 kg
13 WATER MAX CONSUMPTION	14,5 l/h @ 200 kPa
16 GAS NOMINAL HEAT INPUT	24 kW
17 TOTAL NOMINAL HEAT INPUT	24 kW
18 CAVITY DIMENSIONS (W - D - H)	716x705x560 mm
20 IP PROTECTION CLASS	IPX4

ITALIANO

01 POTENZA	1 kW
03 FREQUENZA	50 / 60 Hz
04 TIPO DI CAVO ALIMENTAZIONE	H07RN-F
05 Ø ESTERNO CAVO DI ALIMENTAZIONE	10 mm
06 TENSIONE / SEZIONE CAVI ALIMENTAZIONE / CORRENTE	220-240 V~1PH+N+PE 3G x 1,5 mm ² Circuit Breaker 10 A I1=4,5 A
10 PRESSIONE ACQUA	150-600 kPa
11 CARICA MAX CIBO	60 kg
13 CONSUMO MAX ACQUA	14,5 l/h @ 200 kPa
16 POTENZA TERMICA NOMINALE GAS	24 kW
17 POTENZA TERMICA NOMINALE TOTALE	24 kW
18 DIMENSIONI CAMERA COTTURA (L - P - H)	716x705x560 mm
20 GRADO PROTEZIONE IP	IPX4

FRANCAIS

01 PUISSANCE ELECTRIQUE	1 kW
03 FREQUENCE	50 / 60 Hz
04 TYPE DE CABLE D'ALIMENTATION	H07RN-F
05 Ø EXTERNE DU CABLE D'ALIMENTATION	10 mm
06 TENSION / SECTION CABLE D'ALIM.	220-240 V~1PH+N+PE 3G x 1,5 mm ² Circuit Breaker 10 A I1=4,5 A
10 PRESSION DE L'EAU	150-600 kPa
11 CHARGE MAXIMALE D'ALIMENT	60 kg
13 CONSOMMATION MAX DE L'EAU	14,5 l/h @ 200 kPa
16 PUISSANCE THERMIQUE NOMINAL GAZ	24 kW
17 TOTAL DEBIT THERMIQUE NOMINAL	24 kW
18 DIMENSIONS CHAMBRE DE CUISSON (L - P - A)	716x705x560 mm
20 INDICE DE PROTECTION IP	IPX4

ESPAÑOL

01 POTENCIA	1 kW
03 FRECUENCIA	50 / 60 Hz
04 TIPO DE CABLE DE ALIMENTACION	H07RN-F
05 Ø CABLE EXTERNO DE ALIMENTACION	10 mm
06 TENSION / SECCION CABLES DE ALIMENTACION	220-240 V~1PH+N+PE 3G x 1,5 mm ² Circuit Breaker 10 A I1=4,5 A
10 PRESION AGUA	150-600 kPa
11 CARGA MAX. DE ALIMENTOS	60 kg
13 CONSUMO MAX DE AGUA	14,5 l/h @ 200 kPa
16 POTENCIA TÉRMICA NOMINAL GAS	24 kW
17 TOTALE POTENCIA TERMICA NOMINAL	24 kW
18 DIMENSIONES CÁMARA DE COCCIÓN (An - Pr - Al)	716x705x560 mm
20 GRADO DE PROTECCION IP	IPX4

DEUTSCH

01 ELEKTRISCHE LEISTUNG	1 kW
03 FREQUENZ	50 / 60 Hz
04 ZULEITUNGSKABELTYP	H07RN-F
05 AUSSENDURCHMESSER DES VERSORGUNGSKABELS	10 mm
06 KABELQUERSCHNITT UND VERSORGUNGSSPANNUNG	220-240 V~1PH+N+PE 3G x 1,5 mm ² Circuit Breaker 10 A I1=4,5 A
10 WASSERDRUCK	150-600 kPa
11 MAX. SPEISENFASSUNGSVERMOGEN	60 kg
13 MAXIMUM WASSERVERBRAUCH	14,5 l/h @ 200 kPa
16 GAS NENNWÄRMELEISTUNG	24 kW
17 NENNWÄRMEBELASTUNG	24 kW
18 GRÖÖE DES KOCHKAMMERS (B - T - H)	716x705x560 mm
20 SCHTZART IP	IPX4



MOD:XEVC-0621-GPLM



ENGLISH - DRAWINGS

2	TERMINAL BOARD POWER SUPPLY
3	UNIPOTENTIAL TERMINAL
6	TECHNICAL DATA PLATE
7	SAFETY THERMOSTAT
8	3/4" THREAD WATER INLET
9	3/4" GAS INLET
10	Rotor.KLEAN CONNECTION
11	CAVITY DRAIN PIPE
12	HOT FUMES EXHAUST CHIMNEY
13	ACCESSORIES CONNECTION
27	COOLING AIR OUTLET
30	COMBUSTION GASSES EXHAUST

ITALIANO - DISEGNI

2	MORSETTIERA ALIMENTAZIONE
3	MORSETTO EQUIPOTENZIALE
6	TARGHETTA DATI TECNICI
7	TERMOSTATO DI SICUREZZA
8	INGRESSO ACQUA 3/4"
9	INGRESSO GAS 3/4"
10	INGRESSO Rotor.KLEAN
11	SCARICO CAMERA DI COTTURA
12	USCITA FUMI CALDI
13	COLLEGAMENTO ACCESSORI
27	USCITA ARIA DI RAFFREDDAMENTO
30	USCITA FUMI COMBUSTI

FRANCAIS - ENCOMBREMEN

2	BOITE A BORNES D'ALIMENTATION
3	SUPPORT BORNE EQUIPOTENTIELLE
6	PLAQUETTE SIGNALÉTIQUE
7	THERMOSTAT DE SÉCURITÉ
8	ARRIVÉ D'EAU FIÉLT 3/4"
9	ARRIVÉ DU GAS 3/4"
10	ENTRÉE Rotor.KLEAN
11	SORTIE DE L'EAU RACCORD
12	SORTIE DES FUMÉES CHAUDES
13	JONCTION DES ACCESSOIRES
27	SORTIE D'EAU DE REFOIDISSEMENT
30	SORTIE DES FUMÉES DE COMBUSTION

ESPAÑOL - DISEÑOS

2	CAJA DE CONEXION
3	SEDE BORNE EQUIPOTENCIAL
6	TARJETA DE CARACTERISTICAS TECNICAS
7	TERMOSTATO DE SEGURIDAD
8	ENTRADA DE AGUA 3/4"
9	ENTRADA DE GAS 3/4"
10	INGRESO Rotor.KLEAN
11	DESCARGA CAMARA DE COCCION
12	SALIDA HUMOS CALIENTES
13	CONEXION ACCESORIOS
27	SALIDA DEL AIRE DE ENFRIAMIENTO
30	SALIDA HUMOS DE COMBUSTIÓN

DEUTSCH - ZEICHNUNGEN

2	ZULEITUNGSKLEMMLEISTE
3	GLEICHPOTENTIELLE KLAMMER
6	TYPENSCHILD
7	SICHERHEITSTHERMOSTAT
8	WASSEREINZUG 3/4" GEWINDE
9	GAS EINZUG 3/4" GEWINDE
10	Rotor.KLEAN EINGANG
11	WASSERAUSLASS GEWINDE
12	ABZUGSHAUBE
13	ZUBEHÖRTEILENVERBINDUNG
27	KÜHLLUFTAustrITT
30	ABGASKAMIN

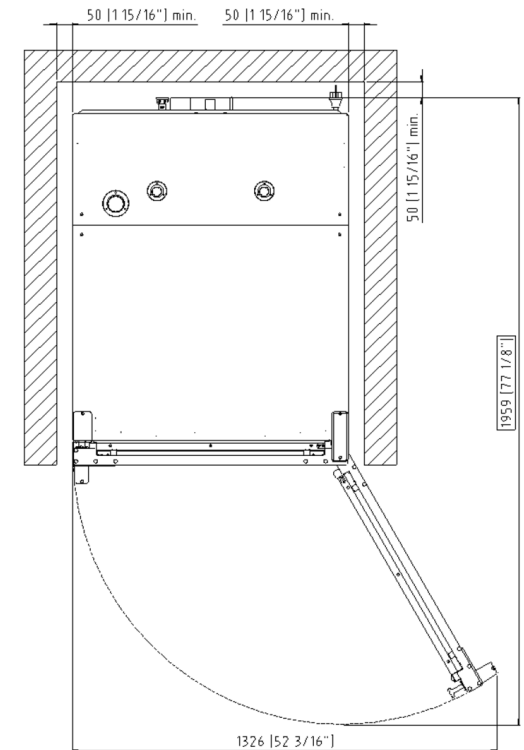
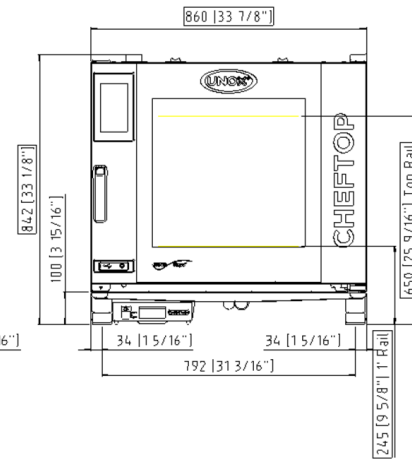
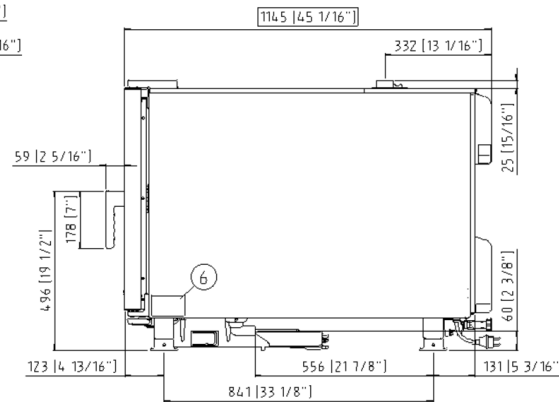
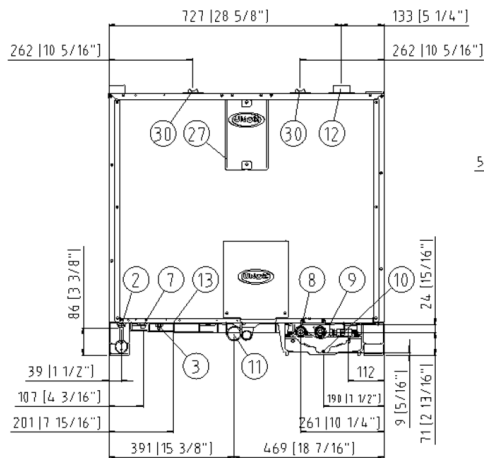

MOD:XEVC-0621-GPLM

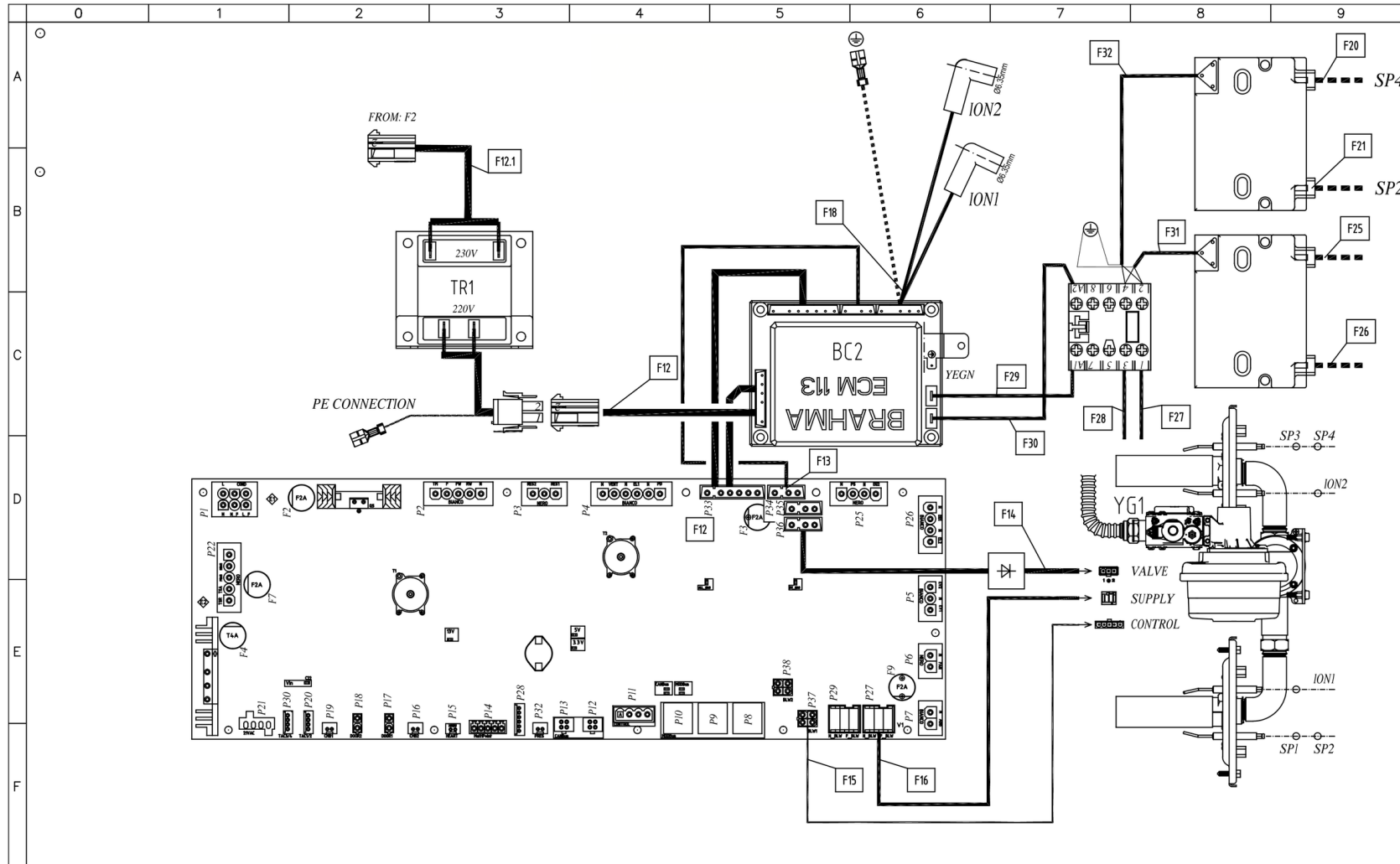

MOD:XEVC-0621-GPLM

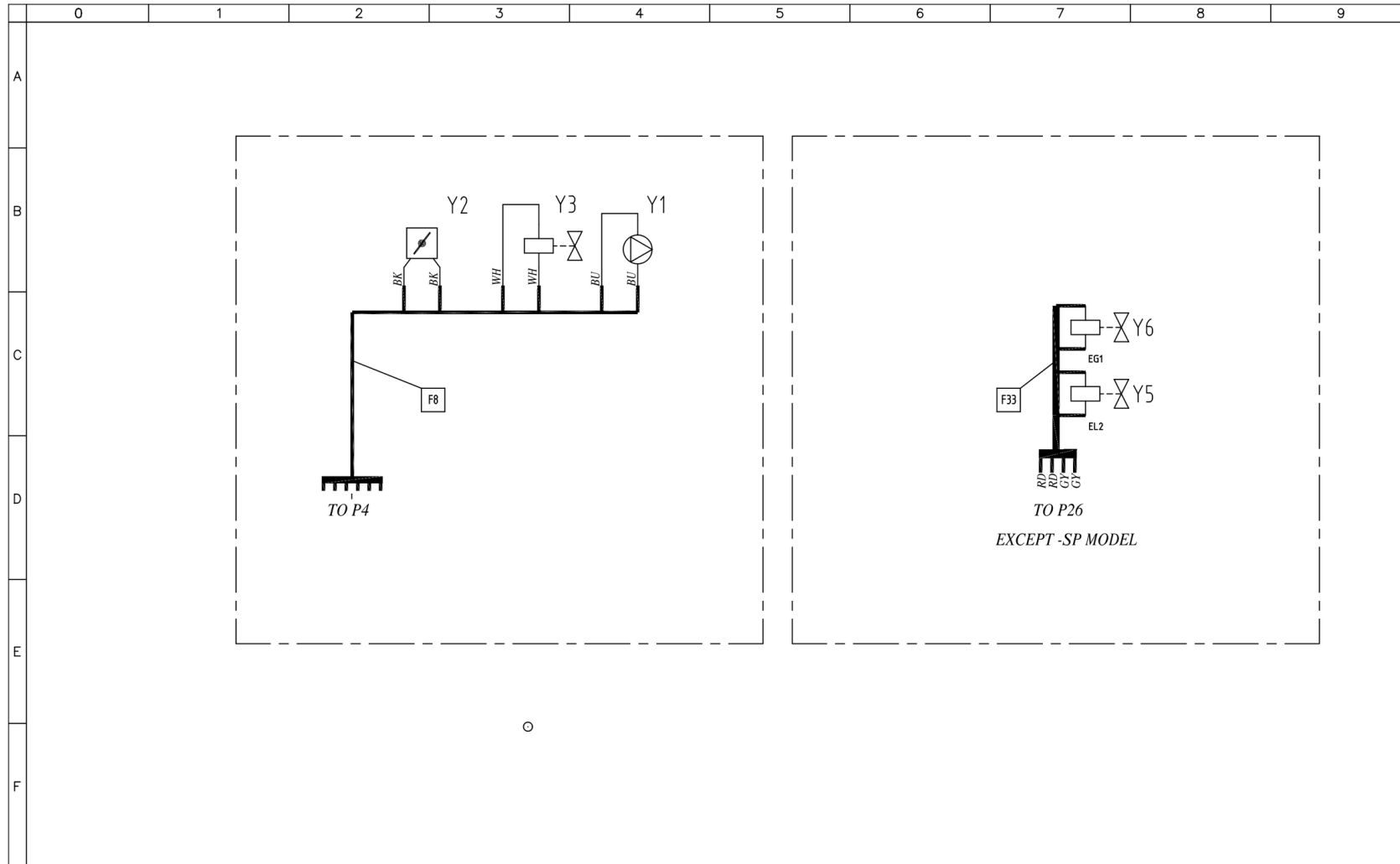

MOD:XEVC-0621-GPLM



	0	1	2	3	4	5	6	7	8	9
A										
	Ⓞ	Sigle		ITALIANO	ENGLISH	FRANCAIS	ESPAÑOL	DEUTSCH		
B	B1	SENSORE VELOCITA MOTORE	MOTOR SPEED SENSOR	CAPTEUR DE VITESSE MOTEUR	SENSOR DE VELOCIDAD MOTOR	GESCHWINDIGKEITSENSOR				
	B3	SONDA CAMERA	TEMPERATURE PROBE	SONDE DE CHAMBRE	SONDA CAMARA	GARRAUMTEMPERATURFUHLER				
	SL1	SCHEDA POTENZA	POWER CARD	CARTE DE PUISSANCE	TARJETA POTENCIA	POWERPLATINE				
	T2,T3	TRASFORMATORE D'ACCENSIONE	IGNITION TRANSFORMER	TRANSFORMATEUR D'ALLUMAGE	TRANSFORMADOR D'INGICION	ZÜNDTRASFORMATOR				
C	TR1	TRASFORMATORE	TRANSFORMER	TRANSFORMATEUR	TRANSFORMADOR	TRASFORMATORE				
	YG1	ELETTROVALVOLA GAS	GAS VALVE	ROBINET DE GAZ	VALVULA DE GAS	GAS VENTIL				
	B2	SONDA AL CUORE	CORE PROBE	SONDE A COEUR	SONDA CORAZON	KERNTEMPERATURFUHLER				
	B4	SONDA CAMERA	TEMPERATURE PROBE	SONDE DE CHAMBRE	SONDA CAMARA	GARRAUMTEMPERATURFUHLER				
D	BC2	CONTROLLO FIAMMA	FLAME CONTROL DEVICE	FLAMME RELEVATRICE	CONTROL LLAMA	FLAMMESTEUERUNG				
	C1,C2	CONDENSATORE	MOTOR CAPACITOR	CONDENSATEUR	CONDENSADOR	KONDENSATOR				
	E1	VENTOLA RAFFREDDAMENTO 12V	COOLING FAN 12V	TURBINE DE REFROIDISSEMENT 12V	TURBINA DE REFRIGERACION 12V	LÜFTER 12V				
	E2	VENTOLA RAFFREDDAMENTO 230V	COOLING FAN 230V	TURBINE DE REFROIDISSEMENT 230V	TURBINA DE REFRIGERACION 230V	LÜFTER 230V				
E	H1	LUCE CAMERA	OVEN LIGHT	ECLAIRAGE DE CHAMBRE	LUZ CAMARA	BELEUCHTUNG				
	K1	TELERUTTORE	CONTACTOR	TELERUPTEUR	TELERRUPTOR	RELAIS				
	PC1	PRESSACAVO PG 13,5	CABLE GLAND / CORDGRIP PG13,5	PRESSE ETOUPE PG13,5	PASACABLES PG13,5	Drüse PG13,5				
	PC2	DADO PRESSACAVO PG13,5	LOCKNUT PG13,5	ECROU PRESSE-ETOUPE PG13,5	NUT PASACABLES PG13,5	ÜBERWURFMUTTER PG13,5				
F	R1,R2,R3,R4	RESISTENZA DI MODULAZIONE VENTILATORE	MOTOR MODULATION RESISTANCE	RESISTANCE DE MODULATION VENTILATEUR	RESISTENCIA MODULACION VELOCIDAD	WIDERSTAND LOW FAN				
	S1	MICRO INTERRUTTORE PORTA	DOOR MICROSWITCH	MICROINTERRUPTEUR DE PORTE	MICROINTERRUPTOR PUERTA	TURKONTAKTSCHALTER				
	S2	PRESSOSTATO	PRESSURE SWITCH	PRESSOSTAT	PRESÓSTATO	DRUCKSCHALTER				
	S3	TERMOSTATO SICUREZZA	SAFETY THERMOSTAT	THERMOSTAT DE SECURITE	TERMOSTATO DE SEGURIDAD	SICHERHEITS THERMOSTAT				
G	SL2	SCHEDA CONTROLLO	CONTROL BOARD	CARTE DE CONTROLE	TARJETA DE CONTROL	KONTROLL PLATINE				
	SL3	SCHEDA I/O - USB	USB - I/O BOARD	USB - CARTE I/O	USB - TARJETA I/O	USB - I/O PLATINE				
	SL4	BRIDGE ETHERNET	BRIDGE ETHERNET	BRIDGE ETHERNET	BRIDGE ETHERNET	BRIDGE ETHERNET				
	TI	TRASFORMATORE	TRANSFORMER	TRANSFORMATEUR	TRANSFORMADOR	TRANSFORMATOR				
H	X1	MORSETTIERA	TERMINAL BLOCK	BORNIER	CONECTOR	KLEMMLEISTE				
	X2	CAVO ALIMENTAZIONE + SCHUKO	POWER CORD + SCHUKO	EPINIERE ET SCHUKO	CABLE Y ENCHUFE SCHUKO	KABEL UND SCHUKO-STECKER				
	Y1	POMPA	PUMP	POMPE	BOMBA	PUMPE				
	Y2	DRY MAXY	DRY MAXY	DRY MAXY	DRY MAXY	DRY MAXY				
I	Y3,Y5,Y6	ELETTROVALVOLA ACQUA	WATER SOLENOID VALVE	ELECTROVANNE EAU	ELECTROVALVULA	ELEKTROVENTIL				
	Y4	ELETTROVALVOLA ACQUA 3 STADI	WATER SOLENOID VALVE 3STAGE	ELECTROVANNE EAU 3 ETAPES	ELECTROVALVULA 3 ETAPAS	ELEKTROVENTIL 3 STUFEN				

MOD:XEVC-0621-GPLM



TAB100026H										Throttle [turns from closed position]	Throttle [Δ turns from G20 setting]	Gas fumes test 1 (MAX)		Gas fumes test 2 (MIN)	
Oven Model	Tray type	Gas type	Nominal GAS power [kW]	Nominal GAS power [MJ/h]	Inlet pressure [mbar]	Ø GAS Valve orifice [mm]	CO2 [% v/v]	CO [ppm]	CO2 [% v/v]			CO [ppm]			
Installation type: A3- Free Single unit B13- Unit with draught diverter B23- Single or Stacked units under hood															
XEVC-0511-GPX - XEVC-0511-GPXM	GN1/1	G110	12,5	45	5 - 40 mbar	-	14	4,5	4,50 ± CO2 ≤ 5,00	4,50 ± CO2 ≤ 5,00	<30	<30			
		G20	15	54	5 - 40 mbar	-	9,5	-	9,10 ± CO2 ≤ 9,50	8,00 ± CO2 ≤ 11,30					
		G25	15	54	5 - 40 mbar	-	9,25	-0,25	9,00 ± CO2 ≤ 9,40	8,00 ± CO2 ≤ 11,30					
		G25.1	15	54	5 - 40 mbar	-	9,5	0	9,60 ± CO2 ≤ 10,00	8,50 ± CO2 ≤ 12,00					
		G25.3	15	54	5 - 40 mbar	-	9,25	-0,25	9,30 ± CO2 ≤ 9,70	8,00 ± CO2 ≤ 11,30					
		G30	15	54	5 - 40 mbar	5,5	8,75	-0,75	11,60 ± CO2 ≤ 12,00	8,50 ± CO2 ≤ 12,50					
		G31	15	54	5 - 40 mbar	5,5	9	-0,5	10,80 ± CO2 ≤ 11,20	8,50 ± CO2 ≤ 12,50					
XEVC-0711-GPX - XEVC-0711-GPXM	GN1/1	G110	16	57,6	5 - 40 mbar	-	14	4,5	4,50 ± CO2 ≤ 5,00	4,50 ± CO2 ≤ 5,00	<30	<30			
		G20	19	68,4	5 - 40 mbar	-	9,5	-	9,30 ± CO2 ≤ 9,70	8,00 ± CO2 ≤ 11,30					
		G25	19	68,4	5 - 40 mbar	-	9,25	-0,25	9,30 ± CO2 ≤ 9,50	8,00 ± CO2 ≤ 11,30					
		G25.1	19	68,4	5 - 40 mbar	-	9,25	-0,25	9,80 ± CO2 ≤ 10,20	8,50 ± CO2 ≤ 12,00					
		G25.3	19	68,4	5 - 40 mbar	-	9,25	-0,25	9,60 ± CO2 ≤ 10,00	8,00 ± CO2 ≤ 11,30					
		G30	19	68,4	5 - 40 mbar	5,5	8,75	-0,75	11,40 ± CO2 ≤ 11,80	8,50 ± CO2 ≤ 12,50					
		G31	19	68,4	5 - 40 mbar	5,5	8,75	-0,75	11,30 ± CO2 ≤ 11,70	8,50 ± CO2 ≤ 12,50					
XEVC-1011-GPX - XEVC-1011-GPXM	GN1/1	G110	17	61,2	5 - 40 mbar	-	14	4,25	4,50 ± CO2 ≤ 5,00	4,50 ± CO2 ≤ 5,00	<30	<30			
		G20	22	79,2	5 - 40 mbar	-	9,75	-	9,20 ± CO2 ≤ 9,60	8,00 ± CO2 ≤ 11,30					
		G25	22	79,2	5 - 40 mbar	-	9,5	-0,25	9,20 ± CO2 ≤ 9,60	8,00 ± CO2 ≤ 11,30					
		G25.1	22	79,2	5 - 40 mbar	-	9,25	-0,5	10,20 ± CO2 ≤ 10,60	8,50 ± CO2 ≤ 12,00					
		G25.3	22	79,2	5 - 40 mbar	-	9,25	-0,5	9,50 ± CO2 ≤ 9,90	8,00 ± CO2 ≤ 11,30					
		G30	22	79,2	5 - 40 mbar	5,5	8,75	-1	11,50 ± CO2 ≤ 11,90	8,50 ± CO2 ≤ 12,50					
		G31	22	79,2	5 - 40 mbar	5,5	9	-0,75	11,40 ± CO2 ≤ 11,80	8,50 ± CO2 ≤ 12,50					
XEVC-2011-GPX	GN1/1	G110	26	93,6	5 - 40 mbar	-	14	4,25	4,50 ± CO2 ≤ 5,00	4,50 ± CO2 ≤ 5,00	<30	<30			
		G20	35	126	5 - 40 mbar	-	9,75	-	9,50 ± CO2 ≤ 9,90	8,00 ± CO2 ≤ 11,30					
		G25	35	126	5 - 40 mbar	-	9,5	-0,25	9,40 ± CO2 ≤ 9,80	8,00 ± CO2 ≤ 11,30					
		G25.1	35	126	5 - 40 mbar	-	9,5	-0,25	10,10 ± CO2 ≤ 10,50	8,50 ± CO2 ≤ 12,00					
		G25.3	35	126	5 - 40 mbar	-	9,75	0	9,40 ± CO2 ≤ 9,80	8,00 ± CO2 ≤ 11,30					
		G30	35	126	5 - 40 mbar	5,5	8,75	-1	11,50 ± CO2 ≤ 11,90	8,50 ± CO2 ≤ 12,50					
		G31	35	126	5 - 40 mbar	5,5	9	-0,75	11,40 ± CO2 ≤ 11,80	8,50 ± CO2 ≤ 12,50					
XEVC-0621-GPX - XEVC-0621-GPXM	GN2/1	G110	16	57,6	5 - 40 mbar	-	14	4,5	4,50 ± CO2 ≤ 5,00	4,50 ± CO2 ≤ 5,00	<30	<30			
		G20	24	86,4	5 - 40 mbar	-	9,5	-	9,20 ± CO2 ≤ 9,60	8,00 ± CO2 ≤ 11,30					
		G25	23	82,8	5 - 40 mbar	-	9,5	0	9,20 ± CO2 ≤ 9,60	8,00 ± CO2 ≤ 11,30					
		G25.1	22	79,2	5 - 40 mbar	-	9,5	0	10,20 ± CO2 ≤ 10,60	8,50 ± CO2 ≤ 12,00					
		G25.3	22	79,2	5 - 40 mbar	-	9,5	0	9,20 ± CO2 ≤ 9,60	8,00 ± CO2 ≤ 11,30					
		G30	24	86,4	5 - 40 mbar	5,5	8,75	-0,75	11,40 ± CO2 ≤ 11,80	8,50 ± CO2 ≤ 12,50					
		G31	24	86,4	5 - 40 mbar	5,5	9	-0,5	11,20 ± CO2 ≤ 11,60	8,50 ± CO2 ≤ 12,50					

MOD:XEVC-0621-GPLM



TAB100026H										Throttle [turns from closed position]	Throttle [Δ turns from G20 setting]	Gas fumes test 1 (MAX)		Gas fumes test 2 (MIN)	
Oven Model	Tray type	Gas type	Nominal GAS power [kW]	Nominal GAS power [MJ/h]	Inlet pressure [mbar]	Ø GAS Valve orifice [mm]	CO2 [% v/v]	CO [ppm]	CO2 [% v/v]			CO [ppm]			
Installation type: A3- Free Single unit B13- Unit with draught diverter B23- Single or Stacked units under hood															
XEVC-1021-GPX - XEVC-1021-GPXM	GN2/1	G110	23	82,8	5 -40 mbar	-	14	4,25	4,50 ≤ CO2 ≤ 5,00	4,50 ≤ CO2 ≤ 5,00	<30	<30			
		G20	35	126	5 -40 mbar	-	9,75	-	9,20 ≤ CO2 ≤ 9,60	8,00 ≤ CO2 ≤ 11,30					
		G25	31,5	113,4	5 -40 mbar	-	9,5	-0,25	9,20 ≤ CO2 ≤ 9,60	8,00 ≤ CO2 ≤ 11,30					
		G25.1	31,5	113,4	5 -40 mbar	-	9,5	-0,25	10,10 ≤ CO2 ≤ 10,50	8,50 ≤ CO2 ≤ 12,00					
		G25.3	31,5	113,4	5 -40 mbar	-	9,25	-0,5	9,60 ≤ CO2 ≤ 10,00	8,00 ≤ CO2 ≤ 11,30					
		G30	35	126	5 -40 mbar	5,5	8,75	-1	11,40 ≤ CO2 ≤ 11,80	8,50 ≤ CO2 ≤ 12,50					
		G31	35	126	5 -40 mbar	5,5	9	-0,75	11,40 ≤ CO2 ≤ 11,80	8,50 ≤ CO2 ≤ 12,50					
XEVC-2021-GPX	GN2/1	G110	38	136,8	5 -40 mbar	-	14	4	4,20 ≤ CO2 ≤ 5,00	4,20 ≤ CO2 ≤ 5,00	<30	<30			
		G20	69	248,4	5 -40 mbar	-	10	-	9,30 ≤ CO2 ≤ 9,70	8,00 ≤ CO2 ≤ 11,30					
		G25	66	237,6	5 -40 mbar	-	9,25	-0,75	9,30 ≤ CO2 ≤ 9,70	8,00 ≤ CO2 ≤ 11,30					
		G25.1	63	226,8	5 -40 mbar	-	9,5	-0,5	10,20 ≤ CO2 ≤ 10,60	8,50 ≤ CO2 ≤ 12,00					
		G25.3	65	234	5 -40 mbar	-	9,25	-0,75	9,70 ≤ CO2 ≤ 10,10	8,00 ≤ CO2 ≤ 11,30					
		G30	70	252	5 -40 mbar	5,5	8,75	-1,25	11,50 ≤ CO2 ≤ 11,90	8,50 ≤ CO2 ≤ 12,50					
		G31	70	252	5 -40 mbar	5,5	9	-1	11,40 ≤ CO2 ≤ 11,80	8,50 ≤ CO2 ≤ 12,50					
XEBC-06EU-GPX - XEBC-06EU-GPXM	600x400	G110	16	57,6	5 -40 mbar	-	14	4,5	4,50 ≤ CO2 ≤ 5,00	4,50 ≤ CO2 ≤ 5,00	<30	<30			
		G20	19	68,4	5 -40 mbar	-	9,5	-	9,30 ≤ CO2 ≤ 9,70	8,00 ≤ CO2 ≤ 11,30					
		G25	19	68,4	5 -40 mbar	-	9,25	-0,25	9,30 ≤ CO2 ≤ 9,50	8,00 ≤ CO2 ≤ 11,30					
		G25.1	19	68,4	5 -40 mbar	-	9,25	-0,25	9,80 ≤ CO2 ≤ 10,20	8,50 ≤ CO2 ≤ 12,00					
		G25.3	19	68,4	5 -40 mbar	-	9,25	-0,25	9,60 ≤ CO2 ≤ 10,00	8,00 ≤ CO2 ≤ 11,30					
		G30	19	68,4	5 -40 mbar	5,5	8,75	-0,75	11,40 ≤ CO2 ≤ 11,80	8,50 ≤ CO2 ≤ 12,50					
		G31	19	68,4	5 -40 mbar	5,5	8,75	-0,75	11,30 ≤ CO2 ≤ 11,70	8,50 ≤ CO2 ≤ 12,50					
XEBC-10EU-GPX - XEBC-10EU-GPXM	600x400	G110	20	72	5 -40 mbar	-	14	4,25	4,50 ≤ CO2 ≤ 5,00	4,50 ≤ CO2 ≤ 5,00	<30	<30			
		G20	25	90	5 -40 mbar	-	9,75	-	9,20 ≤ CO2 ≤ 9,60	8,00 ≤ CO2 ≤ 11,30					
		G25	24	86,4	5 -40 mbar	-	9,5	-0,25	9,30 ≤ CO2 ≤ 9,70	8,00 ≤ CO2 ≤ 11,30					
		G25.1	23	82,8	5 -40 mbar	-	9,25	-0,5	10,20 ≤ CO2 ≤ 10,60	8,50 ≤ CO2 ≤ 12,00					
		G25.3	21	75,6	5 -40 mbar	-	9,25	-0,5	9,30 ≤ CO2 ≤ 9,70	8,00 ≤ CO2 ≤ 11,30					
		G30	25	90	5 -40 mbar	5,5	9	-0,75	11,50 ≤ CO2 ≤ 11,90	8,50 ≤ CO2 ≤ 12,50					
		G31	25	90	5 -40 mbar	5,5	9	-0,75	11,40 ≤ CO2 ≤ 11,80	8,50 ≤ CO2 ≤ 12,50					
XEBC-16EU-GPX	600x400	G110	26	93,6	5 -40 mbar	-	14	4,25	4,50 ≤ CO2 ≤ 5,00	4,50 ≤ CO2 ≤ 5,00	<30	<30			
		G20	35	126	5 -40 mbar	-	9,75	-	9,50 ≤ CO2 ≤ 9,90	8,00 ≤ CO2 ≤ 11,30					
		G25	35	126	5 -40 mbar	-	9,5	-0,25	9,40 ≤ CO2 ≤ 9,80	8,00 ≤ CO2 ≤ 11,30					
		G25.1	35	126	5 -40 mbar	-	9,5	-0,25	10,10 ≤ CO2 ≤ 10,50	8,50 ≤ CO2 ≤ 12,00					
		G25.3	35	126	5 -40 mbar	-	9,75	0	9,40 ≤ CO2 ≤ 9,80	8,00 ≤ CO2 ≤ 11,30					
		G30	35	126	5 -40 mbar	5,5	8,75	-1	11,50 ≤ CO2 ≤ 11,90	8,50 ≤ CO2 ≤ 12,50					
		G31	35	126	5 -40 mbar	5,5	9	-0,75	11,40 ≤ CO2 ≤ 11,80	8,50 ≤ CO2 ≤ 12,50					