

# DISPLAY | Espositori da banco

ESPOSITORI RISCALDATI DA BANCO

## RH 120

HOT  
SHOWCASE



DETTAGLI



Basamento in  
acciaio inox



Doppio vetro  
anti-dispersione



Luce LED interna



## CARATTERISTICHE GENERALI

Espositore riscaldato da banco 120 Lt.	•
Vetro curvo e basamento in acciaio inox	•
Vetro temperato con cornice trasparente	•
Termostato meccanico	•
Termometro analogico	•
Luce interna LED	•
Porte scorrevoli posteriori	•
Ripiani regolabili cromati (N.3 Pcs)	•
N.4 supporti fissi assemblati sotto il basamento	•

## SPECIFICHE TECNICHE

Capacità	120 L
Temperatura	+30° ~ +90°C
Consumo	N/A kWh/24h
Potenza Nominale	1100 W
Rumorosità	15 dB(A)
Peso Netto	48 Kg
Peso Lordo	55 Kg
Dimensioni Esterne (LxPxH mm)	692x582x685
Dimensioni Interne (LxPxH mm)	662x505x430
Dimensioni Imballo (LxPxH mm)	749x627x851
Quantità di carico 20'/40'/40'HQ	81/162/162

## CERTIFICAZIONI

CE  RoHS

## INGOMBRO PRODOTTO

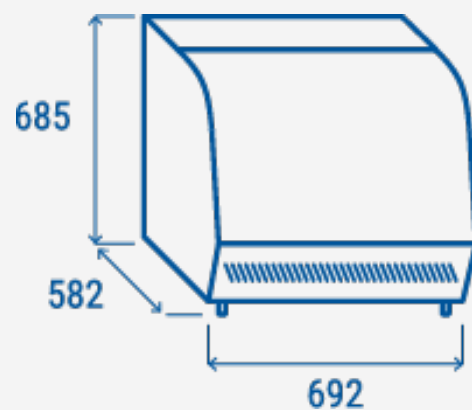

COOL HEAD EUROPE   
We make the world a cooler place

[www.coolheadeurope.com](http://www.coolheadeurope.com)