

FREEZER | Freezer da banco

FREEZER VERTICALI

RNG 50

CUSTOMIZATION AVAILABLE
 PERSONALIZZAZIONE DISPONIBILE

DETTAGLI



CARATTERISTICHE GENERALI

Freezer verticale a 50 Lt.	•
Armadio in acciaio verniciato bianco sia interno che esterno	•
Refrigerazione statica	•
Sbrinamento manuale	•
Schiumatura in Ciclopentano (60mm di spessore per lato)	•
Guarnizione Estraibile	•
Luce interna LED	•
Triplo vetro temperato di sicurezza con resistenza elettrica	•
Porta autochiudente	•
Cornice della porta in alluminio verniciato con maniglia integrata	•
Serratura di serie	•
Ripiani regolabili: 2 Pcs	•
N.4 Piedini regolabili	•
Classe energetica: C	•

SPECIFICHE TECNICHE

Capacità	50 L
Temperatura	L2 (-12°C--18°C)
Consumo	2.53 kWh/24h
Potenza Nominale	156 W
Rumorosità	45 dB(A)
Peso Netto	40 Kg
Peso Lordo	45 Kg
Dimensioni Esterne (LxPxH mm)	570x535x530
Dimensioni Interne (LxPxH mm)	450x420x380
Dimensioni Imballo (LxPxH mm)	610x580x580
Quantità di carico 20'/40'/40'HQ	144/304/304

CERTIFICAZIONI



 RoHS

INGOMBRO PRODOTTO

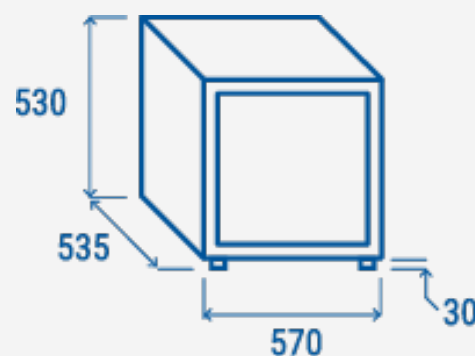
COOL HEAD EUROPE 
 We make the world a cooler place

www.coolheadeurope.com